

Automotive Applications

Oiles bearings are superior in automotive applications and make vehicles realize technological advance by high durability. In addition, these bearings can improve quietness, driving comfort and produce smooth steering operation feeling by appropriate friction.

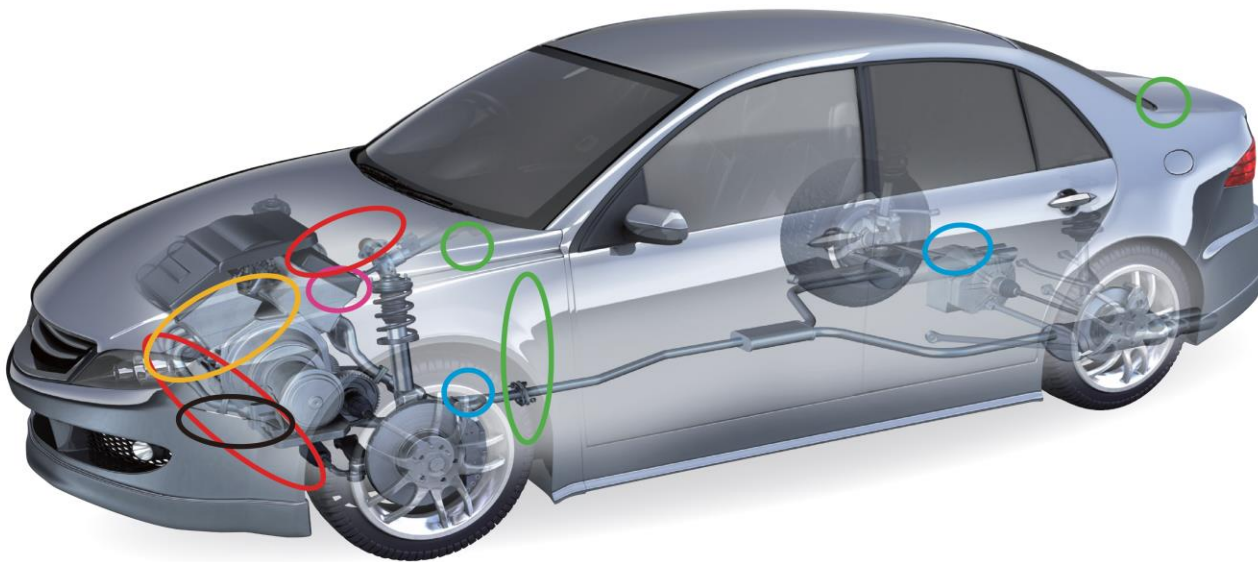

PEDAL – Hysteresis Units



SEAT – Dampers (Orifice type, Viscous Shear type)



Suspension System

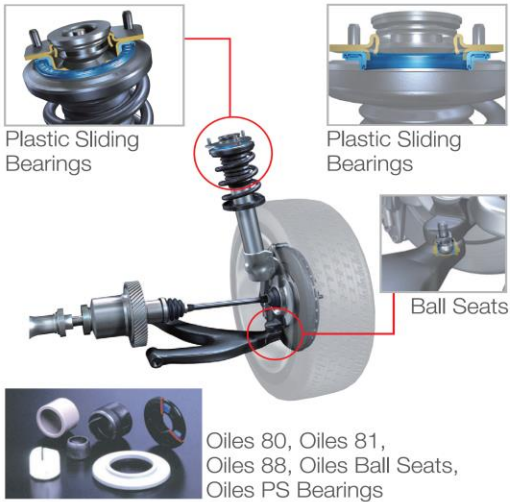

Control System

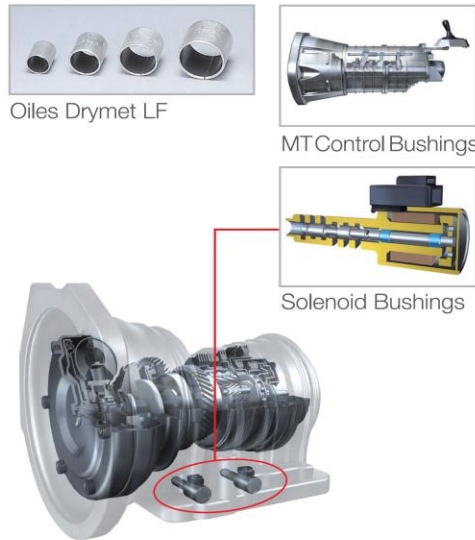

Body System



Steering System

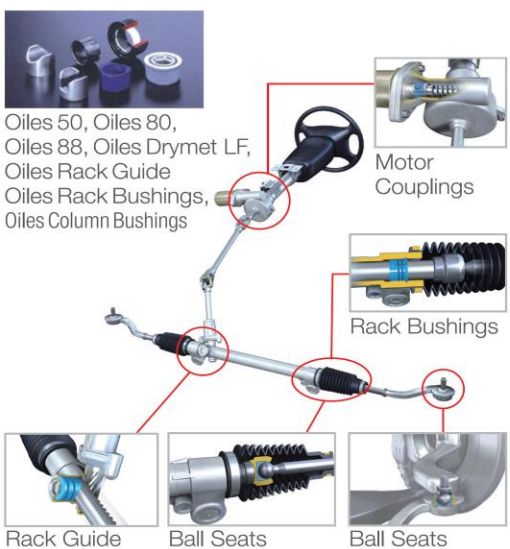

Exhaust System

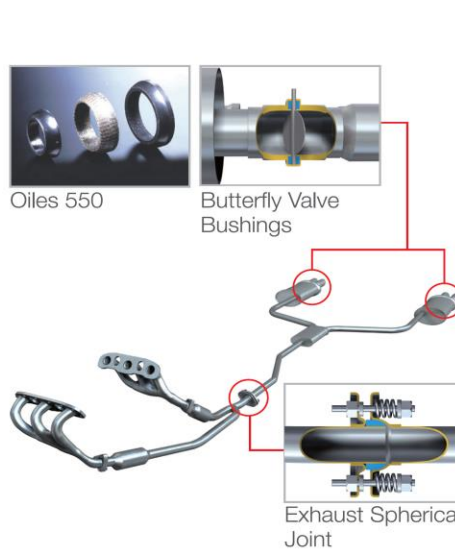

Powertrain System

